

**DAC80**  
**DAC80P**

## Monolithic 12-Bit DIGITAL-TO-ANALOG CONVERTERS

### FEATURES

- **INDUSTRY STANDARD PINOUT**
- **FULL  $\pm 10V$  SWING WITH  $V_{CC} = \pm 12VDC$**
- **DIGITAL INPUTS ARE TTL- AND CMOS-COMPATIBLE**
- **GUARANTEED SPECIFICATIONS WITH  $\pm 12V$  AND  $\pm 15V$  SUPPLIES**
- **$\pm 1/2LSB$  MAXIMUM NONLINEARITY:  $0^\circ C$  to  $+70^\circ C$**
- **SETTLING TIME:  $4\mu s$  max to  $\pm 0.01\%$  of Full Scale**
- **GUARANTEED MONOTONICITY:  $0^\circ C$  to  $+70^\circ C$**
- **TWO PACKAGE OPTIONS: Hermetic side-brazed ceramic and low-cost molded plastic**

resistors, as well as low integral and differential linearity errors. Innovative circuit design enables the DAC80 to operate at supply voltages as low as  $\pm 11.4V$  with no loss in performance or accuracy over any range of output voltage. The lower power dissipation of this 118-mil by 121-mil chip results in higher reliability and greater long term stability.

Burr-Brown has further enhanced the reliability of the monolithic DAC80 by offering a hermetic, side-brazed, ceramic package. In addition, ease of use has been enhanced by eliminating the need for a +5V logic power supply.

For applications requiring both reliability and low cost, the DAC80P in a molded plastic package offers the same electrical performance over temperature as the ceramic model. The DAC80P is available with voltage output only.

For designs that require a wider temperature range, see Burr-Brown models DAC85H and DAC87H.

### DESCRIPTION

This monolithic digital-to-analog converter is pin-for-pin equivalent to the industry standard DAC80 first introduced by Burr-Brown. Its single-chip design includes the output amplifier and provides a highly stable reference capable of supplying up to 2.5mA to an external load without degradation of D/A performance.

This converter uses proven circuit techniques to provide accurate and reliable performance over temperature and power supply variations. The use of a buried zener diode as the basis for the internal reference contributes to the high stability and low noise of the device. Advanced methods of laser trimming result in precision output current and output amplifier feedback

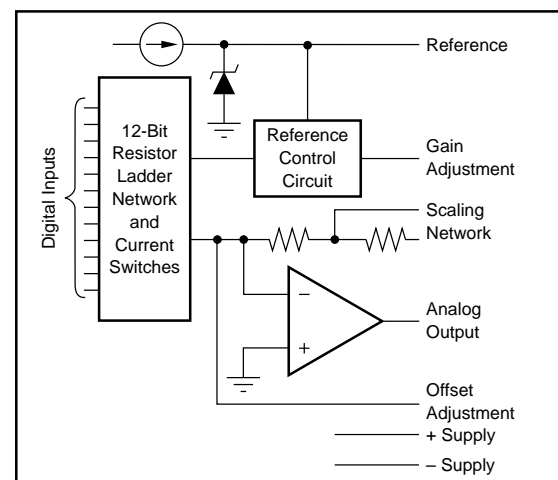

International Airport Industrial Park • Mailing Address: PO Box 11400 • Tucson, AZ 85734 • Street Address: 6730 S. Tucson Blvd. • Tucson, AZ 85706  
Tel: (520) 746-1111 • Twx: 910-952-1111 • Cable: BBRCORP • Telex: 066-6491 • FAX: (520) 889-1510 • Immediate Product Info: (800) 548-6132

# SPECIFICATIONS

## ELECTRICAL

Typical at +25°C and  $\pm V_{CC} = 12V$  or  $15V$  unless otherwise noted.

| PARAMETER   | DAC80      |                                   |             | UNITS                   |
|---|------------|-----------------------------------|-------------|-------------------------|
|   | MIN        | TYP                               | MAX         |                         |
| <b>DIGITAL INPUT</b>  |            |                                   |             |                         |
| Resolution  |            |                                   | 12          | Bits                    |
| Logic Levels (0°C to +70°C) <sup>(1)</sup> :                      |            |                                   |             |                         |
| $V_{IH}$ (Logic "1")  | +2         |                                   | +16.5       | VDC                     |
| $V_{IL}$ (Logic "0")  | 0          |                                   | +0.8        | VDC                     |
| $I_{IH}$ ( $V_{IN} = +2.4V$ )                                     |            |                                   | +20         | $\mu A$                 |
| $I_{IL}$ ( $V_{IN} = +0.4V$ )                                     |            |                                   | -180        | $\mu A$                 |
| <b>ACCURACY</b> (at +25°C)  |            |                                   |             |                         |
| Linearity Error   |            | $\pm 1/4$                         | $\pm 1/2$   | LSB                     |
| Differential Linearity Error                                      |            | $\pm 1/2$                         | $\pm 3/4$   | LSB                     |
| Gain Error <sup>(2)</sup>   |            | $\pm 0.1$                         | $\pm 0.3$   | %                       |
| Offset Error <sup>(2)</sup>                                       |            | $\pm 0.05$                        | $\pm 0.15$  | % of FSR <sup>(3)</sup> |
| <b>DRIFT</b> (0°C to +70°C) <sup>(4)</sup>                        |            |                                   |             |                         |
| Total Bipolar Drift (includes gain, offset, and linearity drifts) |            | $\pm 10$                          | $\pm 25$    | ppm of FSR/°C           |
| Total Error Over 0°C to +70°C <sup>(5)</sup>                      |            |                                   |             |                         |
| Unipolar  |            | $\pm 0.06$                        | $\pm 0.15$  | % of FSR                |
| Bipolar   |            | $\pm 0.06$                        | $\pm 0.12$  | % of FSR                |
| Gain: Including Internal Reference                                |            | $\pm 10$                          | $\pm 30$    | ppm/°C                  |
| Excluding Internal Reference                                      |            | $\pm 5$                           | $\pm 10$    | ppm/°C                  |
| Unipolar Offset   |            | $\pm 1$                           | $\pm 3$     | ppm of FSR/°C           |
| Bipolar Offset  |            | $\pm 7$                           | $\pm 15$    | ppm of FSR/°C           |
| Differential Linearity 0°C to +70°C                               |            | $\pm 1/2$                         | $\pm 3/4$   | LSB                     |
| Linearity Error 0°C to +70°C                                      |            | $\pm 1/4$                         | $\pm 1/2$   | LSB                     |
| Monotonicity Guaranteed   | 0          |                                   | +70         | °C                      |
| <b>CONVERSION SPEED, <math>V_{OUT}</math> Models</b>              |            |                                   |             |                         |
| Settling Time to $\pm 0.01\%$ of FSR                              |            |                                   |             |                         |
| For FSR Change (2k $\Omega$    500pF Load)                        |            |                                   |             |                         |
| with 10k $\Omega$ Feedback  |            | 3                                 | 4           | $\mu s$                 |
| with 5k $\Omega$ Feedback   |            | 2                                 | 3           | $\mu s$                 |
| For 1LSB Change   |            | 1                                 |             | $\mu s$                 |
| Slew Rate   | 10         |                                   |             | V/ $\mu s$              |
| <b>CONVERSION SPEED, <math>I_{OUT}</math> Models</b>              |            |                                   |             |                         |
| Settling Time to $\pm 0.01\%$ of FSR                              |            |                                   |             |                         |
| For FSR change: 10 $\Omega$ to 100 $\Omega$ Load                  |            | 300                               |             | ns                      |
| 1k $\Omega$ Load  |            | 1                                 |             | $\mu s$                 |
| <b>ANALOG OUTPUT, <math>V_{OUT}</math> Models</b>                 |            |                                   |             |                         |
| Ranges  |            | $\pm 2.5, \pm 5, \pm 10, +5, +10$ |             | V                       |
| Output Current <sup>(6)</sup>                                     | $\pm 5$    |                                   |             | mA                      |
| Output Impedance (DC)   |            | 0.05                              |             | $\Omega$                |
| Short Circuit to Common, Duration <sup>(7)</sup>                  |            | Indefinite                        |             |                         |
| <b>ANALOG OUTPUT, <math>I_{OUT}</math> Models</b>                 |            |                                   |             |                         |
| Ranges: Bipolar   | $\pm 0.96$ | $\pm 1.0$                         | $\pm 1.04$  | mA                      |
| Unipolar  | -1.96      | -2.0                              | -2.04       | mA                      |
| Output Impedance: Bipolar   | 2.6        | 3.2                               | 3.7         | k $\Omega$              |
| Unipolar  | 4.6        | 6.6                               | 8.6         | k $\Omega$              |
| Compliance  | -2.5       |                                   | +2.5        | V                       |
| <b>REFERENCE VOLTAGE OUTPUT</b>                                   |            |                                   |             |                         |
| External Current (constant load)                                  | +6.23      | +6.30                             | +6.37       | V                       |
| Drift vs Temperature  |            | $\pm 10$                          | 2.5         | mA                      |
| Output Impedance  |            | 1                                 | $\pm 20$    | ppm/°C                  |
| <b>POWER SUPPLY SENSITIVITY</b>                                   |            |                                   |             |                         |
| $V_{CC} = \pm 12VDC$ or $\pm 15VDC$                               |            | $\pm 0.002$                       | $\pm 0.006$ | % FSR/ % $V_{CC}$       |
| <b>POWER SUPPLY REQUIREMENTS</b>                                  |            |                                   |             |                         |
| $\pm V_{CC}$  | $\pm 11.4$ |                                   | $\pm 16.5$  | VDC                     |
| Supply Drain (no load): + $V_{CC}$                                |            | 8                                 | 12          | mA                      |
| - $V_{CC}$  |            | 15                                | 20          | mA                      |
| Power Dissipation ( $V_{CC} = \pm 15VDC$ )                        |            | 345                               | 480         | mW                      |
| <b>TEMPERATURE RANGE</b>  |            |                                   |             |                         |
| Specification   | 0          |                                   | +70         | °C                      |
| Operating   | -25        |                                   | +85         | °C                      |
| Storage: Plastic DIP  | -60        |                                   | +100        | °C                      |
| Ceramic DIP   | -65        |                                   | +150        | °C                      |

NOTES: (1) Refer to "Logic Input Compatibility" section. (2) Adjustable to zero with external trim potentiometer. (3) FSR means full scale range and is 20V for  $\pm 10V$  range, 10V for  $\pm 5V$  range for  $V_{OUT}$  models; 2mA for  $I_{OUT}$  models. (4) To maintain drift spec, internal feedback resistors must be used. (5) Includes the effects of gain, offset and linearity drift. Gain and offset errors externally adjusted to zero at +25°C. (6) For  $\pm V_{CC}$  less than  $\pm 12VDC$ , limit output current load to  $\pm 2.5mA$  to maintain  $\pm 10V$  full scale output voltage swing. For output range of  $\pm 5V$  or less, the output current is  $\pm 5mA$  over entire  $\pm V_{CC}$  range. (7) Short circuit current is 40mA, max.

## FUNCTIONAL DIAGRAM AND PIN ASSIGNMENTS

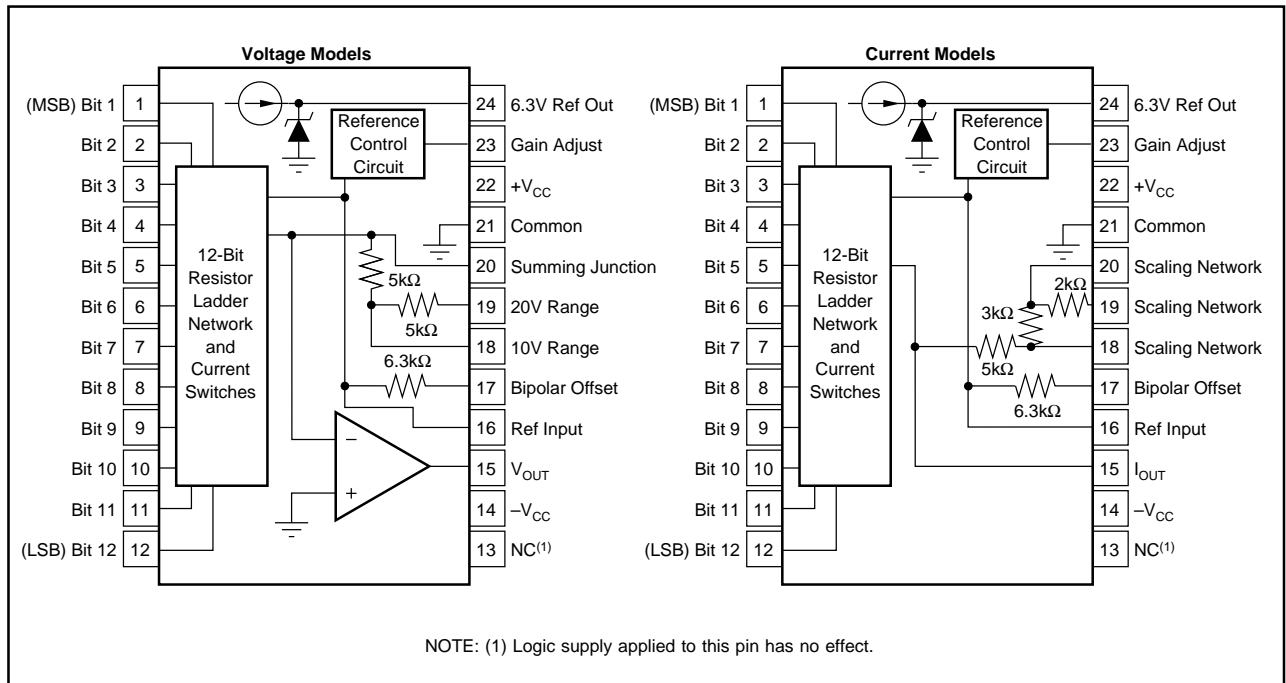

### ABSOLUTE MAXIMUM RATINGS

|   |                  |
|---|------------------|
| +V <sub>CC</sub> to Common .....                      | 0V to +18V       |
| -V <sub>CC</sub> to Common .....                      | 0V to -18V       |
| Digital Data Inputs to Common .....                   | -1V to +18V      |
| Reference Output to Common .....                      | ±V <sub>CC</sub> |
| Reference Input to Common .....                       | ±V <sub>CC</sub> |
| Bipolar Offset to Common .....                        | ±V <sub>CC</sub> |
| 10V Range R to Common .....                           | ±V <sub>CC</sub> |
| 20V Range R to Common .....                           | ±V <sub>CC</sub> |
| External Voltage to DAC Output .....                  | -5V to +5V       |
| Lead Temperature (soldering, 10s) .....               | +300°C           |
| Max Junction Temperature .....                        | 165°C            |
| Thermal Resistance, $\theta_{JA}$ : Plastic DIP ..... | 100°C/W          |
| Ceramic DIP .....                                     | 65°C/W           |

**Stresses above those listed under "Absolute Maximum Ratings" may cause permanent damage to the device. Exposure to absolute maximum conditions for extended periods may affect device reliability.**

### PACKAGE INFORMATION

| MODEL  | PACKAGE            | PACKAGE DRAWING NUMBER <sup>(1)</sup> |
|--------|--------------------|---------------------------------------|
| DAC80P | 24-Pin Plastic DIP | 167                                   |
| DAC80  | 24-Pin Ceramic DIP | 125                                   |

NOTE: (1) For detailed drawing and dimension table, please see end of data sheet, or Appendix D of Burr-Brown IC Data Book.

### BURN-IN SCREENING

Burn-in screening is an option available for the models indicated in the Ordering Information table. Burn-in duration is 160 hours at the maximum specified grade operating temperature (or equivalent combination of time and temperature).

All units are tested after burn-in to ensure that grade specifications are met. To order burn-in, add "-BI" to the base model number.

### ORDERING INFORMATION

| MODEL        | PACKAGE     | OUTPUT  |
|--------------|-------------|---------|
| DAC80-CBI-I  | Ceramic DIP | Current |
| DAC80Z-CBI-I | Ceramic DIP | Current |
| DAC80-CBI-V  | Ceramic DIP | Voltage |
| DAC80Z-CBI-V | Ceramic DIP | Voltage |
| DAC80P-CBI-V | Plastic DIP | Voltage |

| BURN-IN SCREENING OPTION |             |                                     |
|--------------------------|-------------|-------------------------------------|
| MODEL                    | PACKAGE     | BURN-IN TEMP. (160h) <sup>(1)</sup> |
| DAC80-CBI-V-BI           | Ceramic DIP | +125°C                              |
| DAC80P-CBI-V-BI          | Plastic DIP | +125°C                              |

NOTE: (1) Or equivalent combination. See text.

## DICE INFORMATION

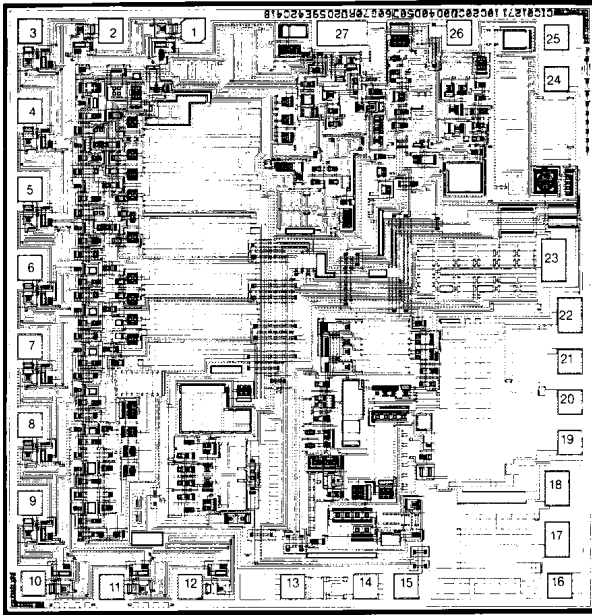

**DAC80KD-V DIE TOPOGRAPHY**

| PAD | FUNCTION     | PAD | FUNCTION       |
|-----|--------------|-----|----------------|
| 1   | Bit 1 (MSB)  | 15  | $-V_{CC}$      |
| 2   | Bit 2        | 16  | $V_{OUT}$      |
| 3   | Bit 3        | 17  | Ref In         |
| 4   | Bit 4        | 18  | Bipolar Offset |
| 5   | Bit 5        | 19  | Scale 10V FSR  |
| 6   | Bit 6        | 20  | Scale 20V FSR  |
| 7   | Bit 7        | 21  | NC             |
| 8   | Bit 8        | 22  | Sum Junct      |
| 9   | Bit 9        | 23  | COM            |
| 10  | Bit 10       | 24  | COM            |
| 11  | Bit 11       | 25  | $+V_{CC}$      |
| 12  | Bit 12 (LSB) | 26  | Gain Adjust    |
| 13  | NC           | 27  | 6.3V Ref Out   |
| 14  | NC           |     |                |

Substrate Bias: Isolated. NC: No Connection

### MECHANICAL INFORMATION

|               | MILS (0.001") | MILLIMETERS       |
|---------------|---------------|-------------------|
| Die Size      | 118 x 121 ± 5 | 3.0 x 3.07 ± 0.13 |
| Die Thickness | 20 ± 3        | 0.51 ± 0.08       |
| Min. Pad Size | 4 x 4         | 0.10 x 0.10       |
| Metalization  |               | Aluminum          |

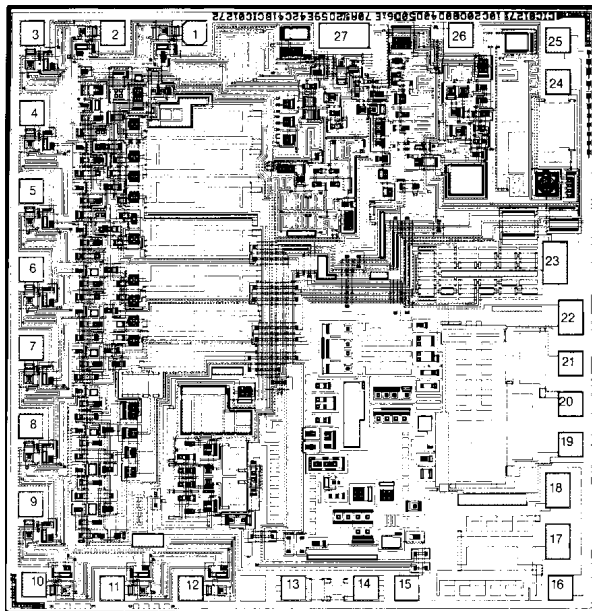

**DAC80KD-I DIE TOPOGRAPHY**

| PAD | FUNCTION     | PAD | FUNCTION       |
|-----|--------------|-----|----------------|
| 1   | Bit 1 (MSB)  | 15  | $-V_{CC}$      |
| 2   | Bit 2        | 16  | $I_{OUT}$      |
| 3   | Bit 3        | 17  | Ref In         |
| 4   | Bit 4        | 18  | Bipolar Offset |
| 5   | Bit 5        | 19  | Scale 10V FSR  |
| 6   | Bit 6        | 20  | Scale 20V FSR  |
| 7   | Bit 7        | 21  | Scale          |
| 8   | Bit 8        | 22  | NC             |
| 9   | Bit 9        | 23  | COM            |
| 10  | Bit 10       | 24  | COM            |
| 11  | Bit 11       | 25  | $+V_{CC}$      |
| 12  | Bit 12 (LSB) | 26  | Gain Adjust    |
| 13  | NC           | 27  | 6.3V Ref Out   |
| 14  | NC           |     |                |

Substrate Bias: Isolated. NC: No Connection

### MECHANICAL INFORMATION

|               | MILS (0.001") | MILLIMETERS       |
|---------------|---------------|-------------------|
| Die Size      | 118 x 121 ± 5 | 3.0 x 3.07 ± 0.13 |
| Die Thickness | 20 ± 3        | 0.51 ± 0.08       |
| Min. Pad Size | 4 x 4         | 0.10 x 0.10       |
| Metalization  |               | Aluminum          |

# DISCUSSION OF SPECIFICATIONS

## DIGITAL INPUT CODES

The DAC80 accepts complementary binary digital input codes. The CBI model may be connected by the user for any one of three complementary codes: CSB, COB, or CTC (see Table I).

| DIGITAL INPUT |          | ANALOG OUTPUT                              |  |  |
|---------------|----------|--|--|--|
| MSB<br>↓      | LSB<br>↓ | CSB<br>Complementary<br>Straight<br>Binary | COB<br>Complementary<br>Offset<br>Binary | CTC <sup>(1)</sup><br>Complementary<br>Two's<br>Complement |
| 0             | 0        | +Full Scale                                | +Full Scale                              | -1LSB  |
| 0             | 1        | +1/2 Full Scale                            | Zero                                     | -Full Scale  |
| 1             | 0        | 1/2 Full Scale -1LSB                       | -1LSB                                    | -Full Scale  |
| 1             | 1        | Zero                                       | -Full Scale                              | Zero   |

NOTE: (1) Invert the MSB of the COB code with an external inverter to obtain CTC code.

TABLE I. Digital Input Codes.

## ACCURACY

Linearity of a D/A converter is the true measure of its performance. The linearity error of the DAC80 is specified over its entire temperature range. This means that the analog output will not vary by more than  $\pm 1/2$ LSB, maximum, from an ideal straight line drawn between the end points (inputs all "1"s and all "0"s) over the specified temperature range of 0°C to +70°C.

Differential linearity error of a D/A converter is the deviation from an ideal 1LSB voltage change from one adjacent output state to the next. A differential linearity error specification of  $\pm 1/2$ LSB means that the output voltage step sizes can range from 1/2LSB to 3/2LSB when the input changes from one adjacent input state to the next.

Monotonicity over a 0°C to +70°C range is guaranteed in the DAC80 to insure that the analog output will increase or remain the same for increasing input digital codes.

## DRIFT

Gain Drift is a measure of the change in the full scale range output over temperature expressed in parts per million per °C (ppm/°C). Gain drift is established by: 1) testing the end point differences for each DAC80 model at 0°C, +25°C, and +70°C; 2) calculating the gain error with respect to the 25°C value, and; 3) dividing by the temperature change. This figure is expressed in ppm/°C and is given in the electrical specifications both with and without internal reference.

Offset Drift is a measure of the actual change in output with all "1"s on the input over the specified temperature range. The offset is measured at 0°C, +25°C, and 70°C. The maximum change in Offset is referenced to the Offset at 25°C and is divided by the temperature range. This drift is expressed in parts per million of full scale range per °C (ppm of FSR/°C).

## SETTLING TIME

Settling time for each DAC80 model is the total time (including slew time) required for the output to settle within an error band around its final value after a change in input (see Figure 1).

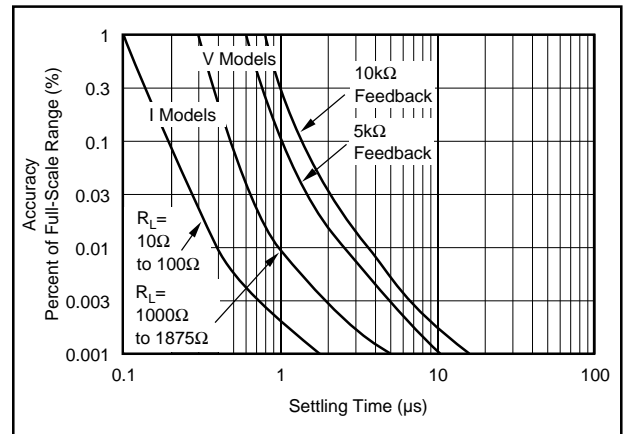

FIGURE 1. Full Scale Range Settling Time vs Accuracy.

## Voltage Output Models

Three settling times are specified to  $\pm 0.01\%$  of full scale range (FSR); two for maximum full scale range changes of 20V, 10V and one for a 1LSB change. The 1LSB change is measured at the major carry (0111...11 to 1000...00), the point at which the worst case settling time occurs.

## Current Output Models

Two settling times are specified to  $\pm 0.01\%$  of FSR. Each is given for current models connected with two different resistive loads: 10Ω to 100Ω and 1000Ω to 1875Ω. Internal resistors are provided for connecting nominal load resistances of approximately 1000Ω to 1800Ω for output voltage range of  $\pm 1$ V and 0 to -2V (see Figures 11 and 12).

## COMPLIANCE

Compliance voltage is the maximum voltage swing allowed on the current output node in order to maintain specified accuracy. The maximum compliance voltage of all current output models is  $\pm 2.5$ V. Maximum safe voltage range of  $\pm 1$ V and 0 to -2V (see Figures 11 and 12).

## POWER SUPPLY SENSITIVITY

Power supply sensitivity is a measure of the effect of a power supply change on the D/A converter output. It is defined as a percent of FSR per percent of change in either the positive or negative supplies about the nominal power supply voltages (see Figure 2).

## REFERENCE SUPPLY

All DAC80 models are supplied with an internal 6.3V reference voltage supply. This voltage (pin 24) has a tolerance of  $\pm 1\%$  and must be connected to the Reference Input

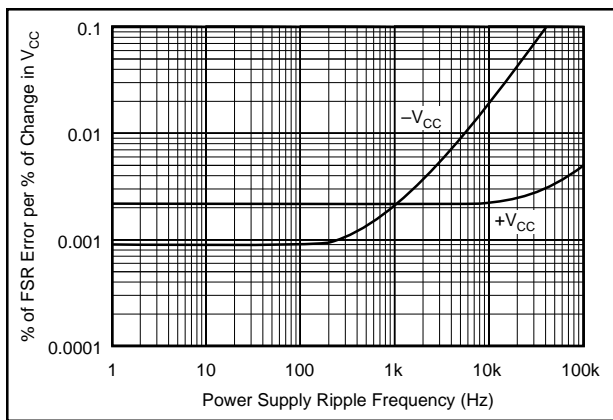

FIGURE 2. Power Supply Rejection vs Power Supply Ripple.

(pin 16) for specified operation. This reference may be used externally also, but external current drain is limited to 2.5mA.

If a varying load is to be driven, an external buffer amplifier is recommended to drive the load in order to isolate bipolar offset from load variations. Gain and bipolar offset adjustments should be made under constant load conditions.

### LOGIC INPUT COMPATIBILITY

DAC80 digital inputs are TTL, LSTTL and 4000B, 54/74HC CMOS compatible. The input switching threshold remains at the TTL threshold over the entire supply range.

Logic "0" input current over temperature is low enough to permit driving DAC80 directly from outputs of 4000B and 54/74C CMOS devices.

## OPERATING INSTRUCTIONS

### POWER SUPPLY CONNECTIONS

Connect power supply voltages as shown in Figure 3. For optimum performance and noise rejection, power supply decoupling capacitors should be added as shown. These capacitors (1 $\mu$ F tantalum) should be located close to the DAC80.

### $\pm 12$ V OPERATION

All DAC80 models can operate over the entire power supply range of  $\pm 11.4$ V to  $\pm 16.5$ V. Even with supply levels dropping to  $\pm 11.4$ V, the DAC80 can swing a full  $\pm 10$ V range, provided the load current is limited to  $\pm 2.5$ mA. With power supplies greater than  $\pm 12$ V, the DAC80 output can be loaded up to  $\pm 5$ mA. For output swing of  $\pm 5$ V or less, the output current is  $\pm 5$ mA, minimum, over the entire  $V_{CC}$  range.

No bleed resistor is needed from  $+V_{CC}$  to pin 24, as was needed with prior hybrid Z versions of DAC80. Existing  $\pm 12$ V applications that are being converted to the monolithic DAC80 must omit the resistor to pin 24 to insure proper operation.

### EXTERNAL OFFSET AND GAIN ADJUSTMENT

Offset and gain may be trimmed by installing external Offset and Gain potentiometers. Connect these potentiometers as shown in Figure 3 and adjust as described below. TCR of the potentiometers should be 100ppm/ $^{\circ}$ C or less. The 3.9M $\Omega$  and 10M $\Omega$  resistors (20% carbon or better) should be located close to the DAC80 to prevent noise pickup. If it is not convenient to use these high value resistors, an equivalent "T" network, as shown in Figure 4, may be substituted.

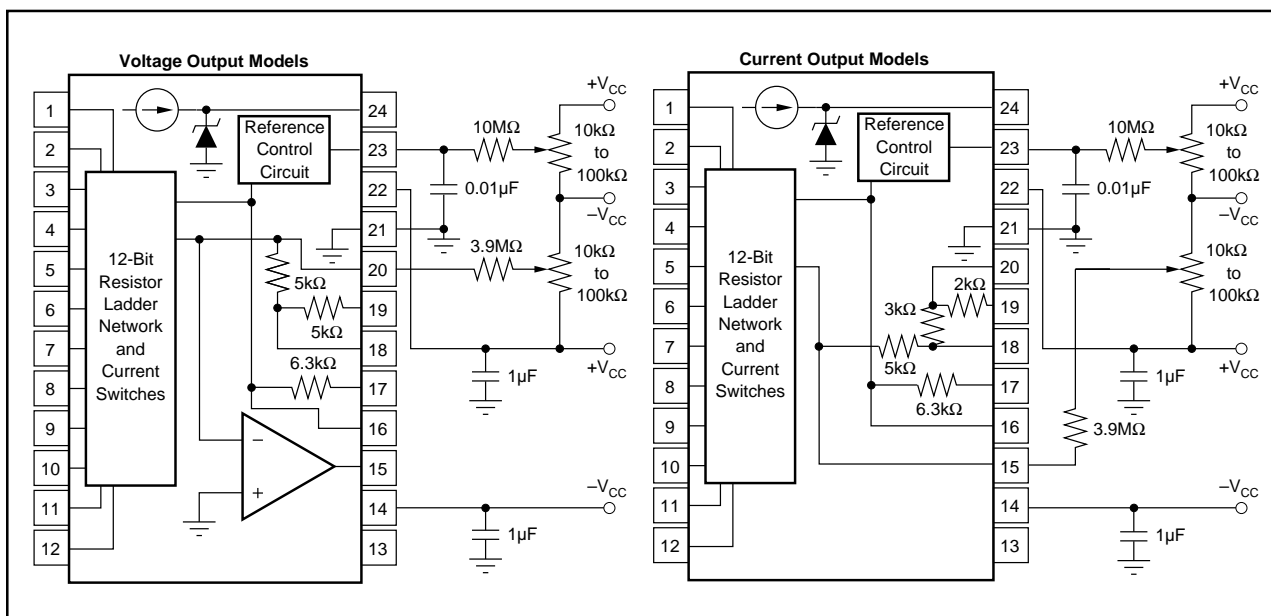

FIGURE 3. Power Supply and External Adjustment Connection Diagrams.

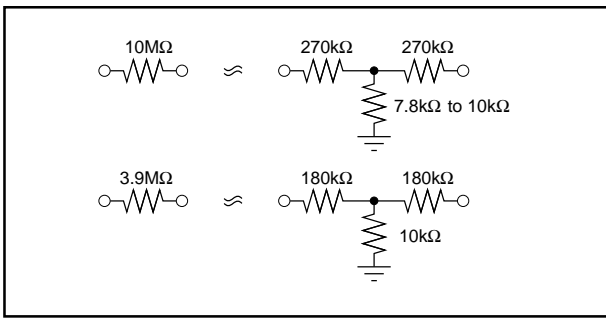

FIGURE 4. Equivalent Resistances.

Existing applications that are converting to the monolithic DAC80 must change the gain trim resistor on pin 23 from 33MΩ to 10MΩ to insure sufficient adjustment range. Pin 23 is a high impedance point and a 0.001μF to 0.01μF ceramic capacitor should be connected from this pin to Common (pin 21) to prevent noise pickup. Refer to Figure 5 for relationship of Offset and Gain adjustments to unipolar and bipolar D/A operation.

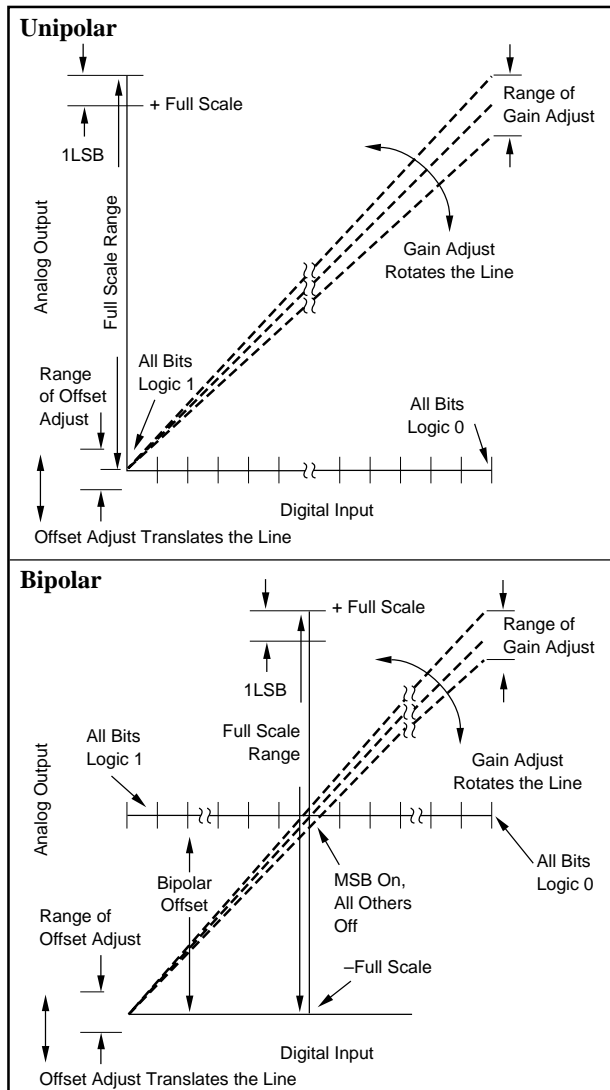

FIGURE 5. Relationship of Offset and Gain Adjustments for a Unipolar and Bipolar D/A Converter.

### Offset Adjustment

For unipolar (CSB) configurations, apply the digital input code that should produce zero potential output and adjust the Offset potentiometer for zero output.

For bipolar (COB, CTC) configurations, apply the digital input code that should produce the maximum negative output. Example: If the Full Scale Range is connected for 20V, the maximum negative output voltage is -10V. See Table II for corresponding codes.

### Gain Adjustment

For either unipolar or bipolar configurations, apply the digital input that should give the maximum positive output. Adjust the Gain potentiometer for this positive full scale output. See Table II for positive full scale voltages and currents.

| DIGITAL INPUT |         | ANALOG OUTPUT          |           |           |           |
|---------------|---------|------------------------|-----------|-----------|-----------|
|               |         | VOLTAGE <sup>(1)</sup> |           | CURRENT   |           |
| MSB           | LSB     | 0 to +10V              | ±10V      | 0 to -2mA | ±1mA      |
| 000000000000  |         | +9.9976V               | +9.9951V  | -1.9995mA | -0.9995mA |
| 011111111111  |         | +5.0000V               | 0.0000V   | -1.0000mA | 0.0000mA  |
| 100000000000  |         | +4.9976V               | -0.0049V  | -0.9995mA | +0.0005mA |
| 111111111111  |         | 0.0000V                | -10.0000V | 0.0000mA  | +1.0000mA |
|               | One LSB | 2.44mV                 | 4.88mV    | 0.488μA   | 0.488μA   |

NOTE: (1) To obtain values for other binary ranges:  
 0 to +5V range divide 0 to +10V range values by 2.  
 ±5V range: divide ±10V range values by 2.  
 ±2.5V range: divide ±10V range values by 4.

TABLE II. Digital Input/Analog Output.

### VOLTAGE OUTPUT MODELS

#### Output Range Connections

Internal scaling resistors provided in the DAC80 may be connected to produce bipolar output voltage ranges of ±10V, ±5V, or ±2.5V; or unipolar output voltage ranges of 0 to +5V or 0 to +10V. See Figure 6.

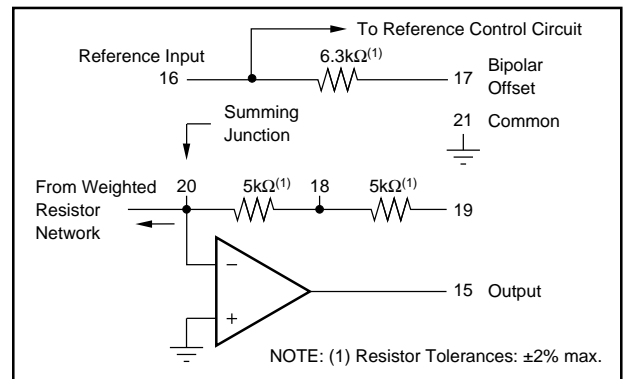

FIGURE 6. Output Amplifier Voltage Range Scaling Circuit.

Gain and offset drift are minimized because of the thermal tracking of the scaling resistors with other internal device components. Connections for various output voltage ranges are shown in Table III. Settling time for a full-scale range change is specified as 4μs for the 20V range and 3μs for the 10V range.

| Output Range | Digital Input Codes | Connect Pin 15 to | Connect Pin 17 to | Connect Pin 19 to | Connect Pin 16 to |
|--------------|---------------------|-------------------|-------------------|-------------------|-------------------|
| ±10          | COB or CTC          | 19                | 20                | 15                | 24                |
| ±5           | COB or CTC          | 18                | 20                | NC                | 24                |
| ±2.5V        | COB or CTC          | 18                | 20                | 20                | 24                |
| 0 to +10V    | CSB                 | 18                | 21                | NC                | 24                |
| 0 to +5V     | CSB                 | 18                | 21                | 20                | 24                |

TABLE III. Output Voltage Range Connections for Voltage Models.

### CURRENT OUTPUT MODELS

The resistive scaling network and equivalent output circuit of the current model differ from the voltage model and are shown in Figures 7 and 8.

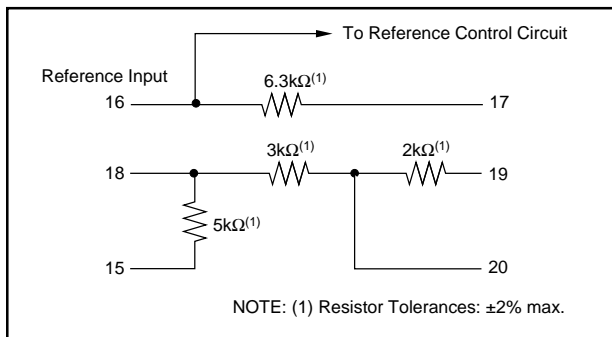

FIGURE 7. Internal Scaling Resistors.

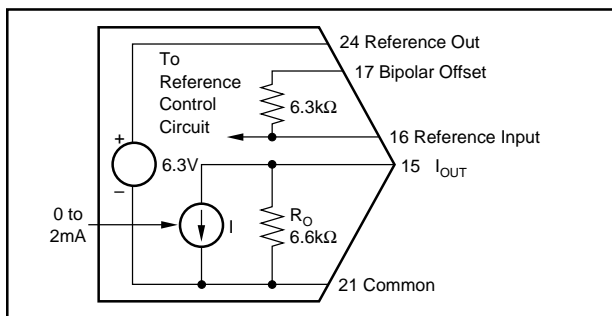

FIGURE 8. Current Output Model Equivalent Output Circuit.

Internal scaling resistors (Figure 7) are provided to scale an external op amp or to configure load resistors for a voltage output. These connections are described in the following sections.

If the internal resistors are not used for voltage scaling, external  $R_L$  (or  $R_F$ ) resistors should have a TCR of  $\pm 25\text{ppm}/^\circ\text{C}$  or less to minimize drift. This will typically add  $\pm 50\text{ppm}/^\circ\text{C}$  plus the TCR of  $R_L$  (or  $R_F$ ) to the total drift.

### Driving An External Op Amp

The current output model DAC80 will drive the summing junction of an op amp used as a current-to-voltage converter to produce an output voltage. See Figure 9.

$$V_{\text{OUT}} = I_{\text{OUT}} \times R_F$$

where  $I_{\text{OUT}}$  is the DAC80 output current and  $R_F$  is the feedback resistor. Using the internal feedback resistors of

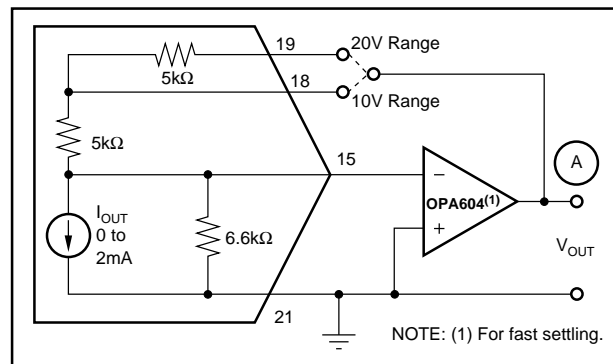

FIGURE 9. External Op-Amp—Using Internal Feedback Resistors.

the current output model DAC80 provides output voltage ranges the same as the voltage model DAC80. To obtain the desired output voltage range when connecting an external op amp, refer to Table IV.

| Output Range | Digital Input Codes | Connect $I_{\text{OUT}}$ to | Connect Pin 17 to | Connect Pin 19 to | Connect Pin 16 to |
|--------------|---------------------|-----------------------------|-------------------|-------------------|-------------------|
| ±10V         | COB or CTC          | 19                          | 15                | $I_{\text{OUT}}$  | 24                |
| ±5V          | COB or CTC          | 18                          | 15                | NC                | 24                |
| ±2.5V        | COB or CTC          | 18                          | 15                | 15                | 24                |
| 0 to +10V    | CSB                 | 18                          | 21                | NC                | 24                |
| 0 to +5V     | CSB                 | 18                          | 21                | 15                | 24                |

TABLE IV. Voltage Range of Current Output.

### Output Larger Than 20V Range

For output voltage ranges larger than  $\pm 10\text{V}$ , a high voltage op amp may be employed with an external feedback resistor. Use  $I_{\text{OUT}}$  value of  $\pm 1\text{mA}$  for bipolar voltage ranges and  $-2\text{mA}$  for unipolar voltage ranges. See Figure 10. Use protection diodes when a high voltage op amp is used.

The feedback resistor,  $R_F$ , should have a temperature coefficient as low as possible. Using an external feedback resistor, overall drift of the circuit increases due to the lack of temperature tracking between  $R_F$  and the internal scaling resistor network. This will typically add  $50\text{ppm}/^\circ\text{C}$  plus  $R_F$  drift to total drift.

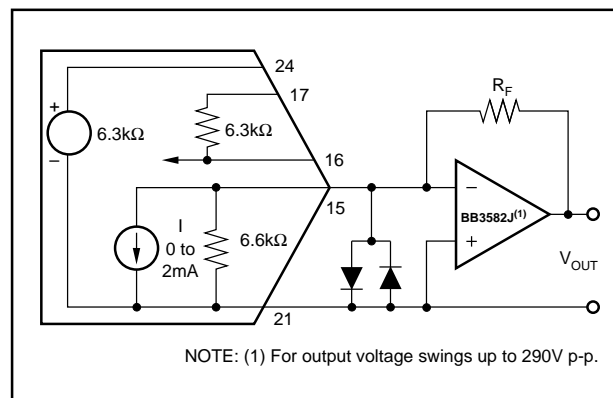

FIGURE 10. External Op-Amp—Using External Feedback Resistors.



### Driving a Resistive Load Unipolar

A load resistance,  $R_L = R_{LI} + R_{LS}$ , connected as shown in Figure 11 will generate a voltage range,  $V_{OUT}$ , determined by:

$$V_{OUT} = -2mA [(R_L \times R_O) \div (R_L + R_O)]$$

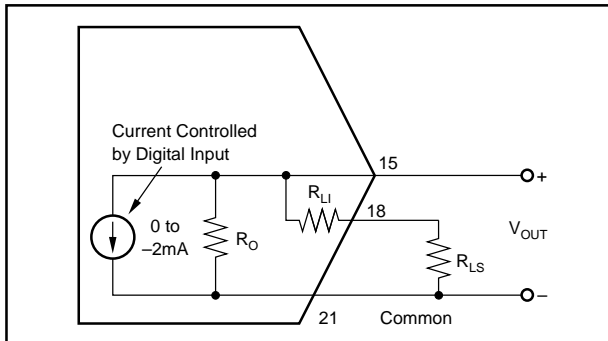

FIGURE 11. Current Output Model Equivalent Circuit Connected for Unipolar Voltage Output with Resistive Load.

The unipolar output impedance  $R_O$  equals  $6.6k\Omega$  (typ) and  $R_{LI}$  is the internal load resistance of  $968\Omega$  (derived by connecting pin 15 to 20 and pin 18 to 19). By choosing  $R_{LS} = 210\Omega$ ,  $R_L = 1178\Omega$ .  $R_L$  in parallel with  $R_O$  yields  $1k\Omega$  total load. This gives an output range of 0 to  $-2V$ . Since  $R_O$  is not exact, initial trimming per Figure 3 may be necessary; also  $R_{LS}$  may be trimmed.

### Driving a Resistive Load Bipolar

The equivalent output circuit for a bipolar output voltage range is shown in Figure 12,  $R_L = R_{LI} + R_{LS}$ .  $V_{OUT}$  is determined by:

$$V_{OUT} = \pm 1mA [(R_O \times R_L) \div (R_O + R_L)]$$

By connecting pin 17 to 15, the output current becomes bipolar ( $\pm 1mA$ ) and the output impedance  $R_O$  becomes  $3.2k\Omega$  ( $6.6k\Omega$  in parallel with  $6.3k\Omega$ ).  $R_{LI}$  is  $1200\Omega$  (derived by connecting pin 15 to 18 and pin 18 to 19). By choosing  $R_{LS} = 225\Omega$ ,  $R_L = 1455\Omega$ .  $R_L$  in parallel with  $R_O$  yields  $1k\Omega$  total load. This gives an output range of  $\pm 1V$ . As indicated above, trimming may be necessary.

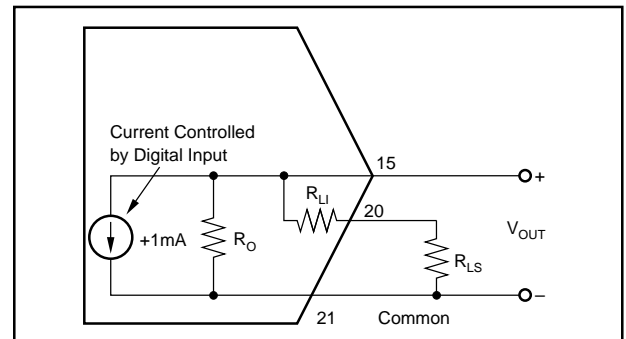

FIGURE 12. Current Output Model Connected for Bipolar Output Voltage with Resistive Load.

The information provided herein is believed to be reliable; however, BURR-BROWN assumes no responsibility for inaccuracies or omissions. BURR-BROWN assumes no responsibility for the use of this information, and all use of such information shall be entirely at the user's own risk. Prices and specifications are subject to change without notice. No patent rights or licenses to any of the circuits described herein are implied or granted to any third party. BURR-BROWN does not authorize or warrant any BURR-BROWN product for use in life support devices and/or systems.

**PACKAGING INFORMATION**

| Orderable Device | Status <sup>(1)</sup> | Package Type | Package Drawing | Pins | Package Qty | Eco Plan <sup>(2)</sup> | Lead/Ball Finish | MSL Peak Temp <sup>(3)</sup> |
|------------------|-----------------------|--------------|-----------------|------|-------------|-------------------------|------------------|------------------------------|
| DAC80-CBI-I      | OBSOLETE              | CDIP SB      | JDM             | 24   |             | TBD                     | Call TI          | Call TI                      |
| DAC80-CBI-V      | OBSOLETE              | CDIP SB      | JDM             | 24   |             | TBD                     | Call TI          | Call TI                      |
| DAC80KD-I        | OBSOLETE              | DIESALE      | Y               | 0    |             | TBD                     | Call TI          | Call TI                      |
| DAC80KD-V        | OBSOLETE              | DIESALE      | Y               | 0    |             | TBD                     | Call TI          | Call TI                      |
| DAC80P-CBI-V     | OBSOLETE              | PDIP         | NTA             | 24   |             | TBD                     | Call TI          | Call TI                      |
| DAC80P-CBI-V-BI  | OBSOLETE              | PDIP         | NTA             | 24   |             | TBD                     | Call TI          | Call TI                      |
| DAC80Z-CBI-V     | OBSOLETE              | CDIP SB      | JD              | 24   |             | TBD                     | Call TI          | Call TI                      |

<sup>(1)</sup> The marketing status values are defined as follows:

**ACTIVE:** Product device recommended for new designs.

**LIFEBUY:** TI has announced that the device will be discontinued, and a lifetime-buy period is in effect.

**NRND:** Not recommended for new designs. Device is in production to support existing customers, but TI does not recommend using this part in a new design.

**PREVIEW:** Device has been announced but is not in production. Samples may or may not be available.

**OBSOLETE:** TI has discontinued the production of the device.

<sup>(2)</sup> Eco Plan - The planned eco-friendly classification: Pb-Free (RoHS), Pb-Free (RoHS Exempt), or Green (RoHS & no Sb/Br) - please check <http://www.ti.com/productcontent> for the latest availability information and additional product content details.

**TBD:** The Pb-Free/Green conversion plan has not been defined.

**Pb-Free (RoHS):** TI's terms "Lead-Free" or "Pb-Free" mean semiconductor products that are compatible with the current RoHS requirements for all 6 substances, including the requirement that lead not exceed 0.1% by weight in homogeneous materials. Where designed to be soldered at high temperatures, TI Pb-Free products are suitable for use in specified lead-free processes.

**Pb-Free (RoHS Exempt):** This component has a RoHS exemption for either 1) lead-based flip-chip solder bumps used between the die and package, or 2) lead-based die adhesive used between the die and leadframe. The component is otherwise considered Pb-Free (RoHS compatible) as defined above.

**Green (RoHS & no Sb/Br):** TI defines "Green" to mean Pb-Free (RoHS compatible), and free of Bromine (Br) and Antimony (Sb) based flame retardants (Br or Sb do not exceed 0.1% by weight in homogeneous material)

<sup>(3)</sup> MSL, Peak Temp. -- The Moisture Sensitivity Level rating according to the JEDEC industry standard classifications, and peak solder temperature.

**Important Information and Disclaimer:**The information provided on this page represents TI's knowledge and belief as of the date that it is provided. TI bases its knowledge and belief on information provided by third parties, and makes no representation or warranty as to the accuracy of such information. Efforts are underway to better integrate information from third parties. TI has taken and continues to take reasonable steps to provide representative and accurate information but may not have conducted destructive testing or chemical analysis on incoming materials and chemicals. TI and TI suppliers consider certain information to be proprietary, and thus CAS numbers and other limited information may not be available for release.

In no event shall TI's liability arising out of such information exceed the total purchase price of the TI part(s) at issue in this document sold by TI to Customer on an annual basis.

## IMPORTANT NOTICE

Texas Instruments Incorporated and its subsidiaries (TI) reserve the right to make corrections, modifications, enhancements, improvements, and other changes to its products and services at any time and to discontinue any product or service without notice. Customers should obtain the latest relevant information before placing orders and should verify that such information is current and complete. All products are sold subject to TI's terms and conditions of sale supplied at the time of order acknowledgment.

TI warrants performance of its hardware products to the specifications applicable at the time of sale in accordance with TI's standard warranty. Testing and other quality control techniques are used to the extent TI deems necessary to support this warranty. Except where mandated by government requirements, testing of all parameters of each product is not necessarily performed.

TI assumes no liability for applications assistance or customer product design. Customers are responsible for their products and applications using TI components. To minimize the risks associated with customer products and applications, customers should provide adequate design and operating safeguards.

TI does not warrant or represent that any license, either express or implied, is granted under any TI patent right, copyright, mask work right, or other TI intellectual property right relating to any combination, machine, or process in which TI products or services are used. Information published by TI regarding third-party products or services does not constitute a license from TI to use such products or services or a warranty or endorsement thereof. Use of such information may require a license from a third party under the patents or other intellectual property of the third party, or a license from TI under the patents or other intellectual property of TI.

Reproduction of TI information in TI data books or data sheets is permissible only if reproduction is without alteration and is accompanied by all associated warranties, conditions, limitations, and notices. Reproduction of this information with alteration is an unfair and deceptive business practice. TI is not responsible or liable for such altered documentation. Information of third parties may be subject to additional restrictions.

Resale of TI products or services with statements different from or beyond the parameters stated by TI for that product or service voids all express and any implied warranties for the associated TI product or service and is an unfair and deceptive business practice. TI is not responsible or liable for any such statements.

TI products are not authorized for use in safety-critical applications (such as life support) where a failure of the TI product would reasonably be expected to cause severe personal injury or death, unless officers of the parties have executed an agreement specifically governing such use. Buyers represent that they have all necessary expertise in the safety and regulatory ramifications of their applications, and acknowledge and agree that they are solely responsible for all legal, regulatory and safety-related requirements concerning their products and any use of TI products in such safety-critical applications, notwithstanding any applications-related information or support that may be provided by TI. Further, Buyers must fully indemnify TI and its representatives against any damages arising out of the use of TI products in such safety-critical applications.

TI products are neither designed nor intended for use in military/aerospace applications or environments unless the TI products are specifically designated by TI as military-grade or "enhanced plastic." Only products designated by TI as military-grade meet military specifications. Buyers acknowledge and agree that any such use of TI products which TI has not designated as military-grade is solely at the Buyer's risk, and that they are solely responsible for compliance with all legal and regulatory requirements in connection with such use.

TI products are neither designed nor intended for use in automotive applications or environments unless the specific TI products are designated by TI as compliant with ISO/TS 16949 requirements. Buyers acknowledge and agree that, if they use any non-designated products in automotive applications, TI will not be responsible for any failure to meet such requirements.

Following are URLs where you can obtain information on other Texas Instruments products and application solutions:

| <b>Products</b>       |  | <b>Applications</b> |  |
|-----------------------|--|---------------------|--|
| Amplifiers            | <a href="http://amplifier.ti.com">amplifier.ti.com</a>             | Audio               | <a href="http://www.ti.com/audio">www.ti.com/audio</a>                   |
| Data Converters       | <a href="http://dataconverter.ti.com">dataconverter.ti.com</a>     | Automotive          | <a href="http://www.ti.com/automotive">www.ti.com/automotive</a>         |
| DSP                   | <a href="http://dsp.ti.com">dsp.ti.com</a>                         | Broadband           | <a href="http://www.ti.com/broadband">www.ti.com/broadband</a>           |
| Interface             | <a href="http://interface.ti.com">interface.ti.com</a>             | Digital Control     | <a href="http://www.ti.com/digitalcontrol">www.ti.com/digitalcontrol</a> |
| Logic                 | <a href="http://logic.ti.com">logic.ti.com</a>                     | Military            | <a href="http://www.ti.com/military">www.ti.com/military</a>             |
| Power Mgmt            | <a href="http://power.ti.com">power.ti.com</a>                     | Optical Networking  | <a href="http://www.ti.com/opticalnetwork">www.ti.com/opticalnetwork</a> |
| Microcontrollers      | <a href="http://microcontroller.ti.com">microcontroller.ti.com</a> | Security            | <a href="http://www.ti.com/security">www.ti.com/security</a>             |
| RFID                  | <a href="http://www.ti-rfid.com">www.ti-rfid.com</a>               | Telephony           | <a href="http://www.ti.com/telephony">www.ti.com/telephony</a>           |
| Low Power<br>Wireless | <a href="http://www.ti.com/lpw">www.ti.com/lpw</a>                 | Video & Imaging     | <a href="http://www.ti.com/video">www.ti.com/video</a>                   |
|                       |  | Wireless            | <a href="http://www.ti.com/wireless">www.ti.com/wireless</a>             |

Mailing Address: Texas Instruments, Post Office Box 655303, Dallas, Texas 75265  
Copyright © 2007, Texas Instruments Incorporated